

CE DECLARATION OF CONFORMITY

Manufacturer: FAAC S.p.A.

Address: Via Benini, 1 - 40069 Zola Predosa BOLOGNA - ITALY

Declares that: 455 D control board,

- conforms to the essential safety requirements of the following directives:

73/23/CEE and subsequent amendment 93/68/CEE.

89/336/CEE and subsequent amendment 92/31/CEE and 93/68/CEE

Additional note:

This product underwent tests in a typical uniform configuration (all products manufactured by FAAC S.p.A.).

Bologna, 01 September 2006

The Managing Director
A. Bassi

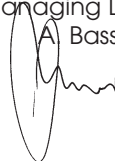

WARNINGS FOR THE INSTALLER GENERAL SAFETY OBLIGATIONS

- 1) ATTENTION! To ensure the safety of people, it is important that you read all the following instructions. Incorrect installation or incorrect use of the product could cause serious harm to people.**
- Carefully read the instructions before beginning to install the product.
- Do not leave packing materials (plastic, polystyrene, etc.) within reach of children as such materials are potential sources of danger.
- Store these instructions for future reference.
- This product was designed and built strictly for the use indicated in this documentation. Any other use, not expressly indicated here, could compromise the good condition/operation of the product and/or be a source of danger.
- FAAC declines all liability caused by improper use or use other than that for which the automated system was intended.
- Do not install the equipment in an explosive atmosphere: the presence of inflammable gas or fumes is a serious danger to safety.
- The mechanical parts must conform to the provisions of Standards EN 12604 and EN 12605. For non-EU countries, to obtain an adequate level of safety, the Standards mentioned above must be observed, in addition to national legal regulations.
- FAAC is not responsible for failure to observe Good Technique in the construction of the closing elements to be motorised, or for any deformation that may occur during use.
- The installation must conform to Standards EN 12453 and EN 12445. For non-EU countries, to obtain an adequate level of safety, the Standards mentioned above must be observed, in addition to national legal regulations.
- Before attempting any job on the system, cut out electrical power.
- The mains power supply of the automated system must be fitted with an all-pole switch with contact opening distance of 3mm or greater. Use of a 6A thermal breaker with all-pole circuit break is recommended.
- Make sure that a differential switch with threshold of 0.03 A is fitted upstream of the system.
- Make sure that the earthing system is perfectly constructed, and connect metal parts of the means of the closure to it.
- The safety devices (EN 12978 standard) protect any danger areas against **mechanical movement Risks**, such as crushing, dragging, and shearing.
- Use of at least one indicator-light (e.g. FAACLIGHT) is recommended for every system, as well as a warning sign adequately secured to the frame structure, in addition to the devices mentioned at point "15".
- FAAC declines all liability as concerns safety and efficient operation of the automated system, if system components not produced by FAAC are used.
- For maintenance, strictly use original parts by FAAC.
- Do not in any way modify the components of the automated system.
- The installer shall supply all information concerning manual operation of the system in case of an emergency, and shall hand over to the user the warnings handbook supplied with the product.
- Do not allow children or adults to stay near the product while it is operating.
- Keep remote controls or other pulse generators away from children, to prevent the automated system from being activated involuntarily.
- Transit is permitted only when the automated system is idle.
- The user must not attempt any kind of repair or direct action whatever and contact qualified personnel only.
- Maintenance: check at least every 6 months the efficiency of the system, particularly the efficiency of the safety devices (including, where foreseen, the operator thrust force) and of the release devices.
- 26) Anything not expressly specified in these instructions is not permitted.**

CONTROL BOARD 455 D

1. WARNINGS

Important: Before attempting any work on the control board (connections, maintenance), always turn off power.

- Install, upstream of the system, a differential thermal breaker with adequate tripping threshold.
- Connect the earth cable to the appropriate terminal on the J3 connector of the equipment (see fig.2).
- Always separate power cables from control and safety cables (push-button, receiver, photocells, etc.). To avoid any electric noise, use separate sheaths or a shielded cable (with earthed shield).

2. TECHNICAL SPECIFICATIONS

Power supply	230 V~ (+6% -10%) - 50 Hz
Absorbed power	10 W
Motor max. load	800 W
Accessories max. load	0,5 A
Electric lock max. load	15 VA
Operating ambient temperature	-20 °C +55 °C
Protection fuses	2 (see fig. 1)
Function logics	Semi-automatic / Automatic / Safety devices / "Stepped" semi-automatic / "Stepped" automatic / "Stepped" Safety devices / Semi-automatic B / Dead-man C
Opening/closing time	Programmable (from 0 to 120 s)
Pause time	Programmable (from 0 to 4 min.)
Closing leaf delay	Programmable (from 0 to 4 min.)
Opening leaf delay	2 s (can be excluded)
Thrust force	Adjustable on 50 levels for each motor
Terminal board inputs	Open / Open free leaf / Stop / Limit-switch Opening safety devices / Closing safety devices / Power supply + Earth
Terminal board outputs	Flashing lamp - Motors - 24 Vdc accessories power supply - 24 Vdc indicator-light - Fail safe - 12 Vac electric lock power supply
Programmable functions	Logic - Pause time - Thrust Force - Torque at initial thrust Opening and closing leaf delay - Reversing stroke - Over-pushing stroke - indicator-light - Pre-flashing - Electric lock - Fail safe - Safety devices logic - Assistance request - Detection time of obstacle or contact point
Learning function	Simple or complete work time learning, with or without Limit-switch and/or Gatecoder.

4. ELECTRIC CONNECTIONS

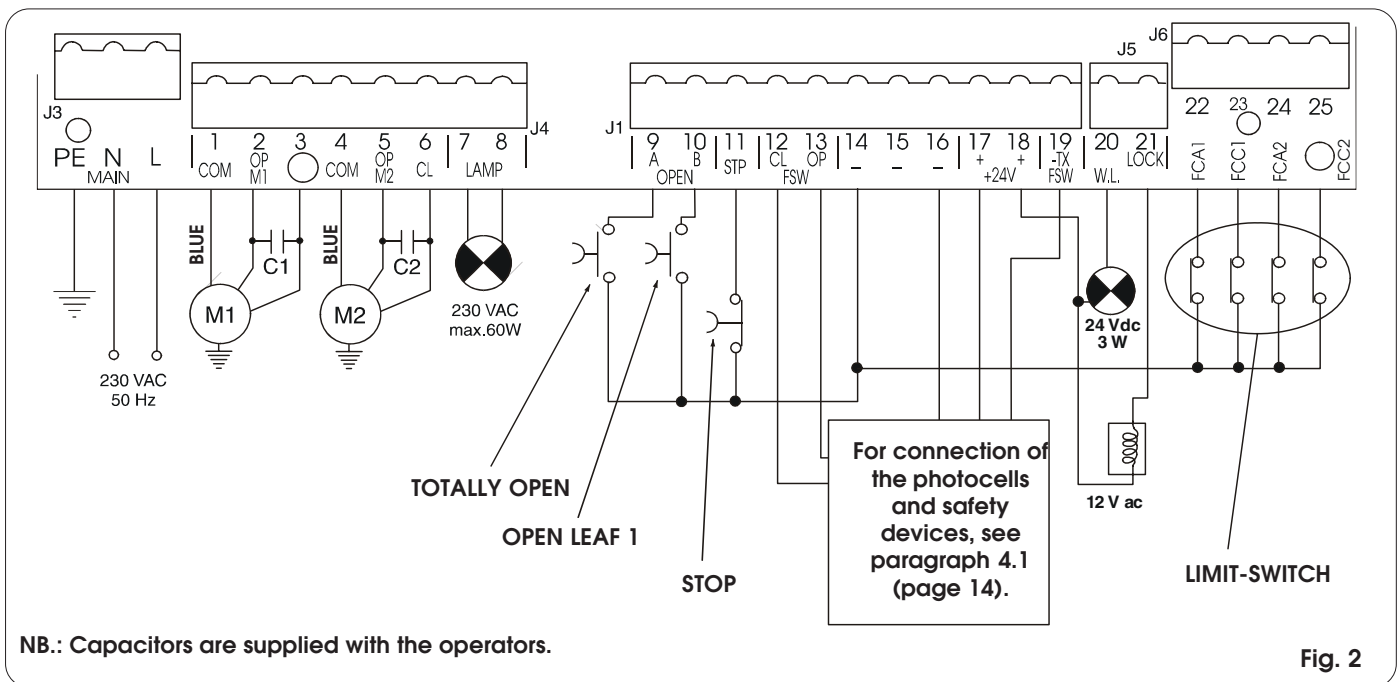

Fig. 2

3. LAYOUT AND COMPONENTS OF 455 D

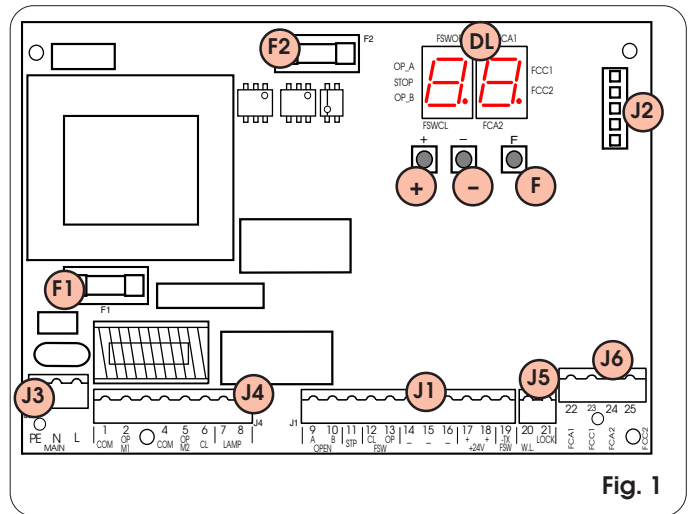

Fig. 1

DL	SIGNALLING AND PROGRAMMING DISPLAY
J1	LOW VOLTAGE TERMINAL BOARD
J2	CONNECTOR FOR DECODER/MINIDEC/RP RECEIVER
J3	230 VAC POWER SUPPLY TERMINAL BOARD
J4	MOTORS AND FLASHING LAMP CONNECTION TERMINAL BOARD
J5	INDICATOR-LIGHT AND ELECTRIC LOCK TERMINAL BOARD
J6	LIMIT-SWITCH AND GATECODER TERMINAL BOARD
F1	MOTORS AND TRANSFORMER PRIMARY WINDING FUSE (F 5A)
F2	LOW VOLTAGE AND ACCESSORIES FUSE (T 800mA)
F	"F" PROGRAMMING PUSH-BUTTON
-	"-" PROGRAMMING PUSH-BUTTON
+	"+" PROGRAMMING PUSH-BUTTON

4.1. CONNECTION OF PHOTOCELLS AND SAFETY DEVICES

Before connecting the photocells (or other devices) we advise you to select the type of operation according to the movement area they have to protect (see fig.3):

Opening safety devices: they operate only during the gate opening movement and, therefore, they are suitable for protecting the area between the opening leaves and fixed obstacles (walls, etc) against the risk of impact and crushing.

Closing safety devices: they operate only during the gate closing movement and, therefore, they are suitable for protecting the closing area against the risk of impact.

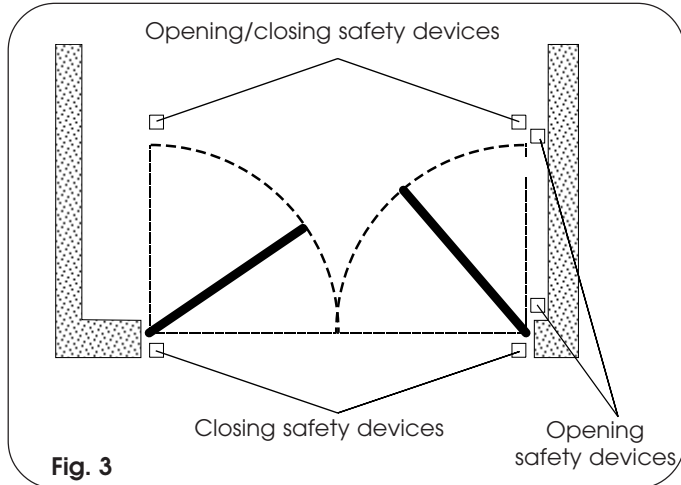

Fig. 3

Opening/closing safety devices: they operate during the gate opening and closing movements and, therefore, they are suitable for the opening and closing areas against the risk of impact.

FAAC recommends use of the lay-out in fig. 4 (in the event of fixed obstacles at opening) or in fig. 5 (no fixed obstacles).

N.B. If two or more devices have the same function (opening or closing), they should be connected to each other in series (see fig. 12). N.C. contacts must be used.

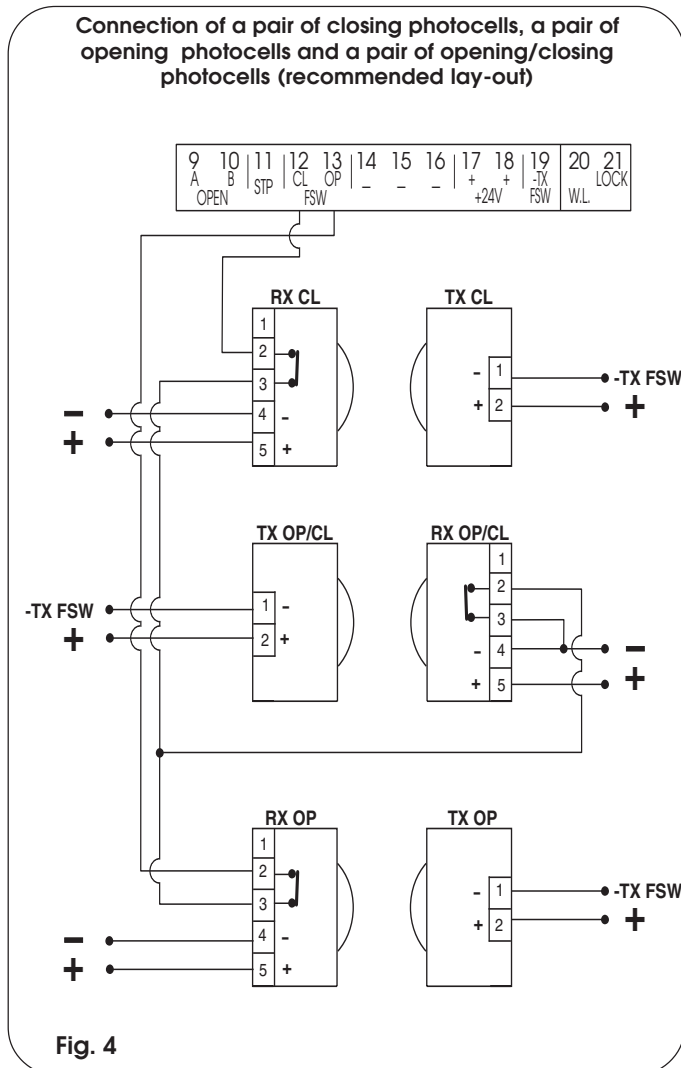

Fig. 4

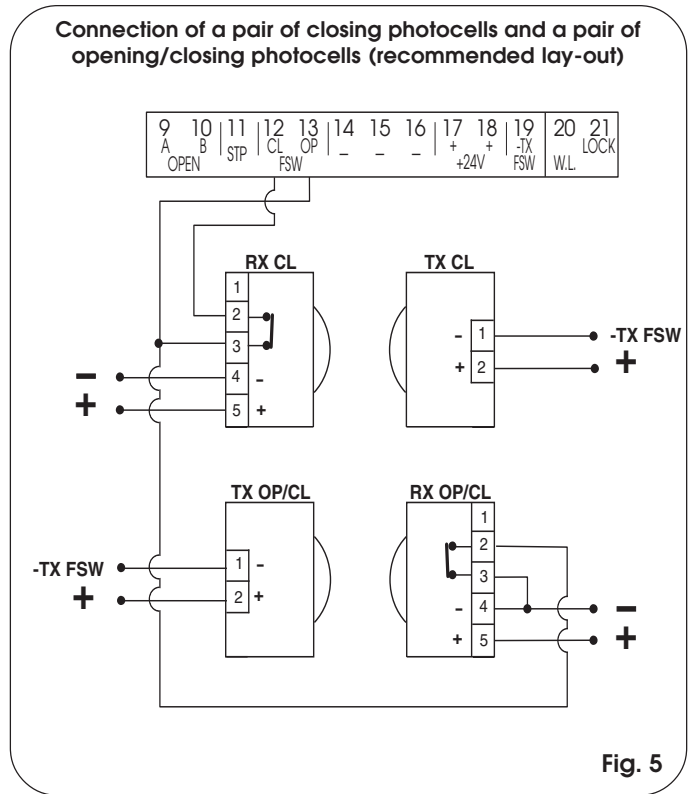

Fig. 5

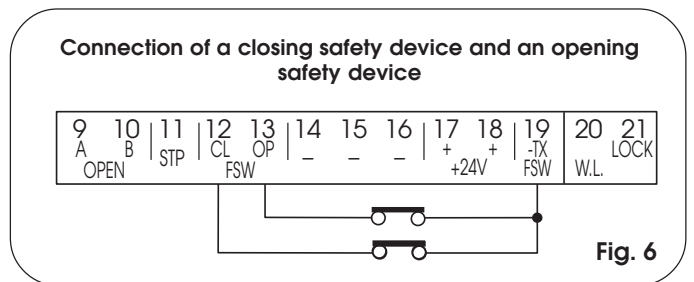

Fig. 6

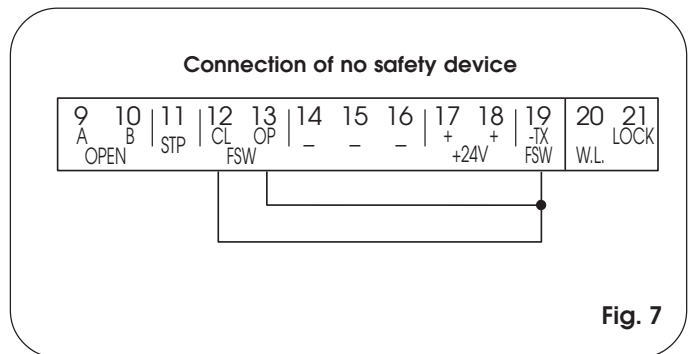

Fig. 7

ENGLISH

Connection of 1 pair of opening photocells

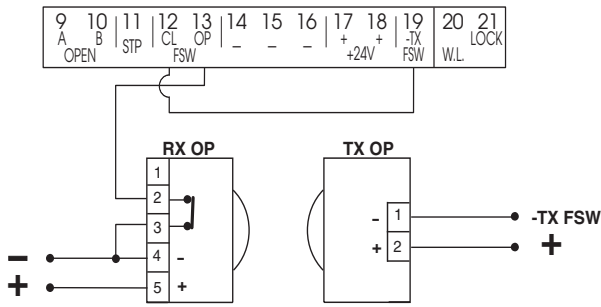

Fig. 8

Connection of 1 pair of closing photocells

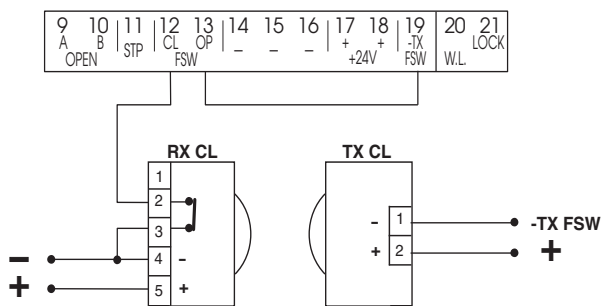

Fig. 9

Connection of a pair of opening photocells and a pair of closing photocells

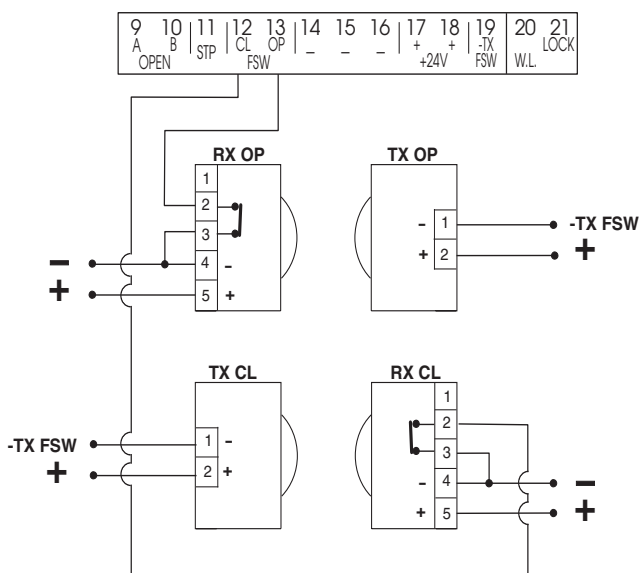

Fig. 10

Connection of two pairs of closing photocells

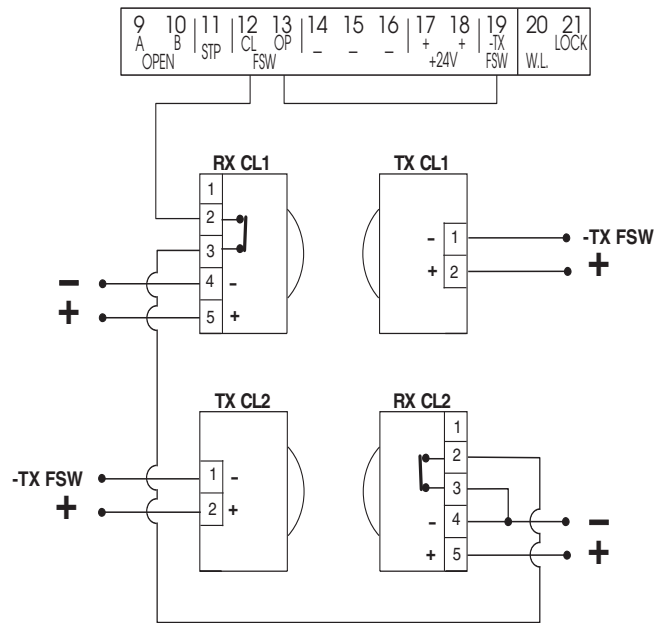

Fig. 11

Connection of 2 N.C. contacts in series
(e.g. Photocells, Stop)

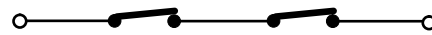

Fig. 12

Connection of 2 N.O. contacts in parallel
(e.g. Open A, Open B)

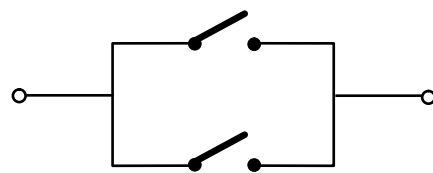

Fig. 13

4.2. TERMINAL BOARD J3 - POWER SUPPLY (FIG. 2)

- PE: Earth connection
- N : 230 V~ power supply (Neutral)
- L : 230 V~ power supply (Line)

NB.: For correct operation, the board must be connected to the earth conductor in the system. Install an adequate differential thermal breaker upstream of the system.

4.3. TERMINAL BOARD J4 - MOTORS AND FLASHING LAMP (FIG. 2)

- M1 : COM / OP / CL: Connection to Motor 1
Can be used in the single-leaf application
- M2 : COM / OP / CL: Connection to Motor 2
Cannot be used in the single-leaf application
- LAMP : Flashing lamp output (230 V ~)

ENGLISH

4.4. TERMINAL BOARD J1 - ACCESSORIES (FIG. 2)

OPEN A - "Total Opening" command (N.O.): any pulse generator (push-button, detector, etc.) which, by closing a contact, commands opening and/or closing of both gate leaves.

To install several full opening pulse generators, connect the N.O. contacts in parallel.

OPEN B - "Partial Opening" command (N.O.) / Closing: any pulse generator (push-button, detector, etc.) which, by closing a contact, commands opening and/or closing of the leaf driven by motor M1. In the B and C logics, it always commands closing of both leaves.

To install several partial opening pulse generators, connect the N.O. contacts in parallel.

STP - STOP contact (N.C.): any device (e.g. a push-button) which, by opening a contact, is able to stop gate movement.

To install several STOP devices, connect the N.C. contacts in series.

NB.: *If STOP devices are not connected, jumper connect the STP terminals and -.*

CLFSW - Closing safety devices contact (N.C.): The purpose of the closing safety devices is to protect the leaf movement area during closing. During closing, in the **E-A-S-EP-AP-SP** logics, the safety devices reverse the movement of the gate leaves, or stop and reverse the movement when they are released (see advanced programming in Chapter 5.2.). During the closing cycle in logics **B** and **C**, they interrupt movement. They never operate during the opening cycle. If the **closing safety devices** operate when the gate is open, they prevent the leaf closing movement.

NB.: *If no closing safety devices are connected, jumper connect terminals CL and -TX FSW (fig. 7).*

OPFSW - Opening safety devices contact (N.C.): The purpose of the opening safety devices is to protect the leaf movement area during opening. During opening, in the **E-A-S-EP-AP-SP** logics, the safety devices reverse the movement of the gate leaves. During the opening cycle in logics **B** and **C**, they interrupt movement. They never operate during the closing cycle.

If the **opening safety devices** operate when the gate is closed, they prevent the leaf opening movement.

NB.: *If no opening safety devices are connected, jumper connect inputs OP and -TX FSW (fig. 7).*

- - Negative for power supply to accessories

± - 24 Vdc - Positive for power supply to accessories

Important: Accessories max. load is 500 mA. To calculate absorption values, refer to the instructions for individual accessories.

-TX FSW - Negative for power supply to photocell transmitters.

If you use this terminal for connecting the negative for supplying power to the photocell transmitters, you may, if necessary, also use the FAIL SAFE function (see advanced programming in Chapter 5.2.).

If this function is enabled, the equipment checks operation of the photocells before every opening or closing cycle.

4.5. TERMINAL BOARD J5 - INDICATOR-LIGHT AND ELECTRIC LOCK (FIG.2)

W.L. - Power supply to indicator-light

Connect a 24 Vdc - 3 W max. indicator-light, if necessary, between this terminal and the +24V supply. To avoid compromising correct operation of the system, **do not exceed** the indicated power.

LOCK - Power supply to electric lock

If necessary, connect a 12 V ac electric lock between this terminal and the +24V supply.

4.6. CONNECTOR J2 - RAPID CONNECTION TO MINIDEC, DECODER AND RP

This is used for rapid connection of Minidec, Decoder and RP receivers (see fig. 14, 15, 16 and 17). Connect the accessory, with the components side facing the inside of the card. Insert and remove after cutting power.

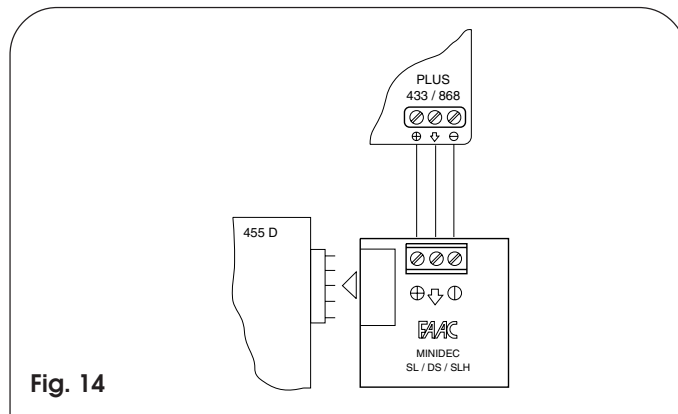

Fig. 14

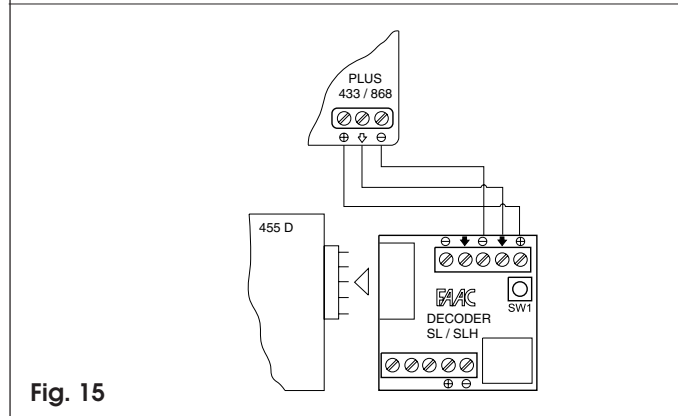

Fig. 15

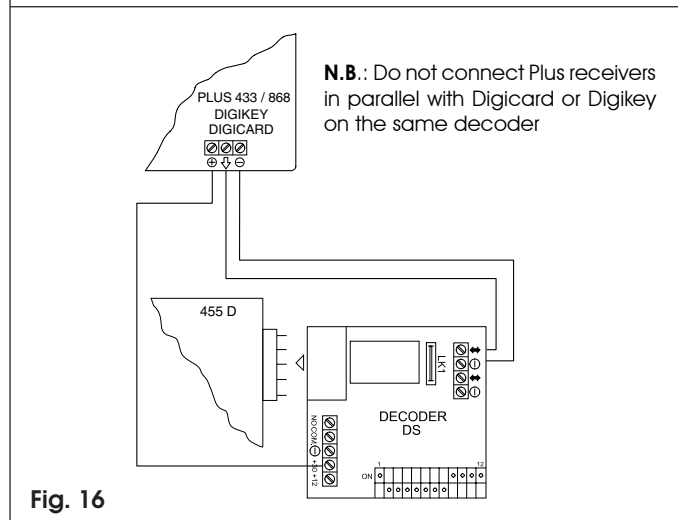

Fig. 16

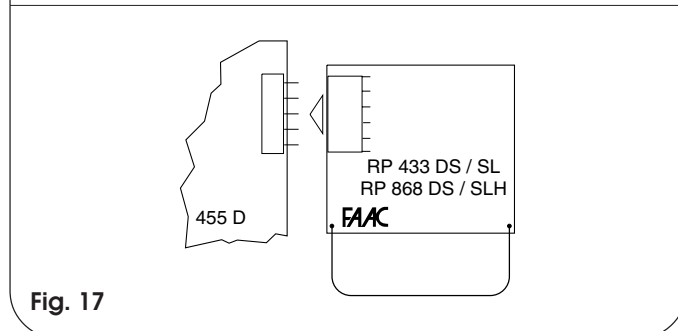

Fig. 17

ENGLISH

4.7. TERMINAL BOARD J6 - LIMIT-SWITCHES AND/OR GATE-CODER (FIG.2)

These inputs are designed for connection of opening and closing limit-switches which, according to type of programming - can command either leaf stop or start of deceleration. Unconnected limit-switches must be jumper connected (if no limit-switch is connected, there is no need to make jumpers). Gatecoders can also be used to detect the leaf's angular position and to thus obtain deceleration and stop positions independent of work time.

Limit-switches and Gatecoders can also be used in combination to stop movement before the mechanical stop limit is reached. To wire, see fig. 18, 19 and 20.

FCA1 - Leaf 1 opening limit-switch

FCC1 - Leaf 1 closing limit-switch

FCA2 - Leaf 2 opening limit-switch

FCC2 - Leaf 2 closing limit-switch

Fig. 18

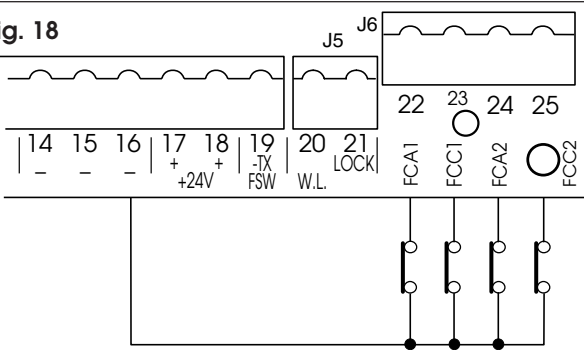

Fig. 19

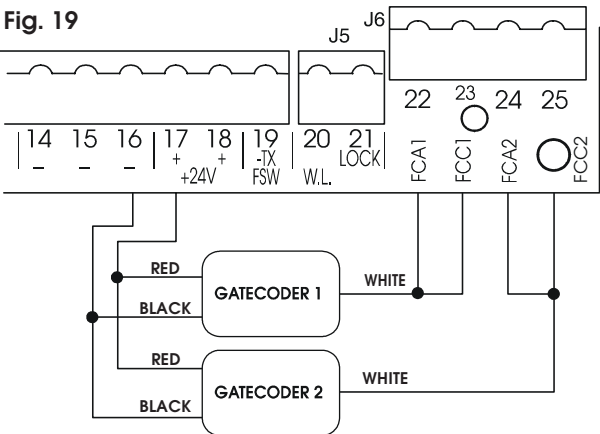
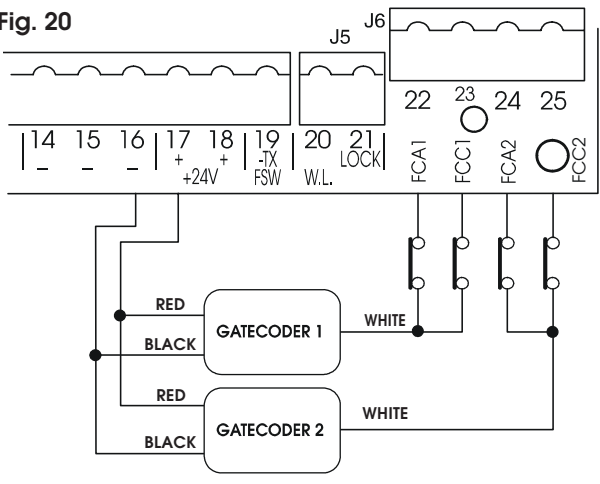

Fig. 20



N.B.: Maximum configurations are shown on the drawings. All intermediate configurations are allowed, using only some elements (only 1 Gatecoder, only 1 limit-switch, 2 Gatecoders and 2 limit-switches etc.). In this case, the unused inputs must be jumpered to earth

5. PROGRAMMING

To program operation of the automated system, you have to access the "PROGRAMMING" mode.

Programming is split into two parts: **BASIC** and **ADVANCED**.

5.1. BASIC PROGRAMMING

To access BASIC PROGRAMMING, press key **F**:

- if you press it (and hold it down), the display shows the name of the first function.
- if you release the key, the display shows the value of the function that can be modified with keys **+** and **-**.
- if you press **F** again (and hold it down), the display shows the name of the next function, etc.
- when you reach the last function, press **F** to exit the program, and the display resumes showing the status of the inputs.

The following table shows the sequence of functions accessible in BASIC PROGRAMMING:

Display	Function	Default
LO	FUNCTION LOGICS (see tab. 3/a - h): = Semi-automatic = Automatic = "Safety" Automatic = "Stepped" Semi-automatic = "Stepped" Automatic = "Safety Stepped" Automatic = "B" Semi-automatic = Dead-man	E
PA	PAUSE TIME: This has effect only if the automatic logic was selected. Adjustable from 0 to 59 sec. in one-second steps. Subsequently, display changes to minutes and tens of seconds (separated by a point) and time is adjusted in 10-second steps, up to the maximum value of 4.1 minutes. E.g. if the display shows 2.5 , pause time is 2 min. and 50 sec.	0
F1	LEAF 1 FORCE : * Adjusts thrust of Motor 1. 1 = minimum force 50 = maximum force (hydraulic)	25
F2	LEAF 2 FORCE : * Adjusts thrust of Motor 2. 1 = minimum force 50 = maximum force (hydraulic)	25
cd	LEAF 1 CLOSING DELAY: Delays closing start of leaf 1 with respect to leaf 2. Adjustable from 0 to 4.1 minutes (see Pause Time).	0
EL	TIME LEARNING (see Chapter 6.3.): Enables the selection between "simple" (automatic) learning and "complete" (manual choice of deceleration and stop points) learning. Simple learning: + ≈ 1 s. Complete learning: + > 3 s.	
ln	Exit from programming and return to display of inputs status.	

* **NB.:** if you are using hydraulic operators, set force to maximum level.



ENGLISH

5.2. ADVANCED PROGRAMMING

To access ADVANCED PROGRAMMING, press key **F** and, as you hold it down, press key **+**:

- if you release key **+**, the display indicates the name of the first function.
- if you release key **F** too, the display shows the value of the function that can be modified with keys **+** and **-**.
- if you press key **F** (and hold it down), the display shows the name of the next function, and if you release it, the value that can be modified with keys **+** and **-** is shown.
- when you reach the last function, press **F** to exit the program, and the display resumes showing the status of the inputs.

The following table shows the sequence of functions accessible in ADVANCED PROGRAMMING:

ADVANCED PROGRAMMING   		
Display	Function	Default
60	MAXIMUM TORQUE AT INITIAL THRUST : The motors operate at maximum torque (ignoring the torque setting) at start of movement. Useful for heavy leaves. 4 = Active no = Disabled	no
c5	LAST STROKE AT CLOSING: The motors are activated at full speed for 1 s to facilitate locking of the electric lock. 4 = Active no = Disabled	no
r5	REVERSING STROKE: Before opening, while the gate is closed, the motors thrust to close for 2 s thus facilitating release of the electric lock. 4 = Active no = Disabled	no
od	LEAF 2 OPENING DELAY (2 s): Enables delayed start (at opening) of leaf 2, avoiding interference between leaves. 4 = Active no = Disabled	no
F5	FAIL SAFE: If this function is activated, it enables a function test of the photocells before any gate movement. If the test fails (photocells not serviceable), the gate does not start the movement. 4 = Active no = Disabled	no
PF	PRE-FLASHING (5 s): Activates the flashing lamp for 5 s before start of movement. 4 = Active no = Disabled	no
EL	ELECTRIC LOCK ON LEAF 2: For using the electric lock on leaf 2 instead of on leaf 1. 4 = Active no = Disabled	no

Display	Function	Default
SP	INDICATOR-LIGHT: If 0 is selected, the output functions as a standard indicator-light (lighted at opening and pause, flashing at closing, and off when gate closed). Different figures correspond to the extra time compared to normal work time (opening or closing) when the output can be used - via a relay - to power a courtesy light. Time can be adjusted from 1 to 59 s in 1 s steps, and from 10 to 41 min. in 10 s steps. 0 = Standard indicator-light from 1 to 41 = Timed output	0
Ph	CLOSING PHOTOCELLS REVERSE AT RELEASE: Enable this function if you want the closing photocells to stop movement and reverse it at release. Default setting is immediate reverse. 4 = Active no = Disabled	no
Ad	A.D.M.A.P. function: If this function is enabled, the safety devices operate in compliance with French standard NFP 25/362. 4 = Active no = Disabled	no
AS	ASSISTANCE REQUEST (combined with next function): If activated, at the end of countdown (settable with the next function i.e. "Cycle programming") it effects 8 s of pre-flashing at every Open pulse (job request). Can be useful for setting scheduled maintenance jobs. 4 = Active no = Disabled	no
nC	CYCLE PROGRAMMING: For setting countdown of system operation cycles. Settable (in thousands) from 0 to 99 thousand cycles. The displayed value is updated as cycles proceed. This function can be used to check use of the board or to exploit the "Assistance request".	0
EC	ANTI-CRUSHING SENSITIVITY: When operating with the gatecoder, it controls anti-crushing sensitivity. 4 = Low no = High. EXTRA WORK TIME: When operating without a gatecoder and limit-switch, if reversing occurs, and if the leaf does not reach its end contact point, you can activate this function to increase work time. 4 = Active no = Disabled	no
In	Exit from programming and return to display of inputs status.	

ENGLISH

NB.: modification of programming parameters comes into effect immediately, whereas definitive memory storage occurs only when you exit programming and return to gate status viewing. If the equipment is powered down before return to status viewing, all modifications will be lost.

To restore the default settings of the programming press the three buttons **+**, **-**, **F** simultaneously and keep them pressed for 5 seconds.

6. START-UP

6.1. LED CHECK

The board has a two-digit display. If out of the "PROGRAMMING" mode, this display is used to indicate status of inputs. Fig. 16 shows how the segments (we'll call these LEDs from now on) of the display exactly correspond to the inputs.

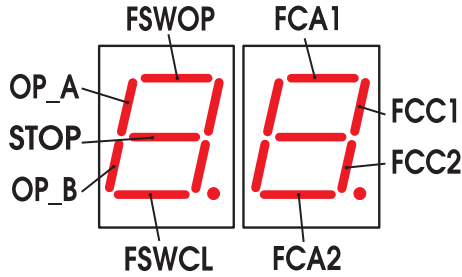

Fig. 21

The table below shows the status of the LEDs in relation to the status of the inputs.

Note the following: **LED LIGHTED** = closed contact
LED OFF = open contact

Check the state of the LEDs as per Table.

Operation of the status signalling LEDs

LEDs	LIGHTED	OFF
OP_A	Command activated	Comando inattivo
OP_B	Command activated	Comando inattivo
STOP	Command inactive	Command activated
FSWCL	Safety devices disengaged	Safety devices engaged
FSWOP	Safety devices disengaged	Safety devices engaged
FCA1 (if used)	Limit-switch free	Limit-switch engaged
FCC1 (if used)	Limit-switch free	Limit-switch engaged
FCC2 (if used)	Limit-switch free	Limit-switch engaged
FCA2 (if used)	Limit-switch free	Limit-switch engaged

NB.: The status of the LEDs while the gate is closed at rest are shown in bold.

6.2. ROTATION DIRECTION AND FORCE CHECK

- 1) Program the functions of the 455 D control board according to need, as shown in Chapter 5.
- 2) Cut power to the electronic control equipment.
- 3) Release the operators and manually move the gate to the mid-point of the opening angle.
- 4) Re-lock the operators.
- 5) Restore power.
- 6) Send an opening command on the OPEN A input (fig.2) and check if the gate leaves are being commanded to open.

N.B.: If the first OPEN A pulse commands a closing, cut power and change over the phases of the electric motor (brown and black wires) on the 455 D terminal board.

- 7) Check power setting of the motors and, if necessary, modify it (see Chapter 5.1).

N.B.: If using hydraulic operators, force should be programmed to maximum level (50)

- 8) Stop leaf movement with a STOP command.
- 9) Release the operators, close the leaves and re-lock the operators.

6.3. LEARNING OF OPERATING TIMES

WARNING:

during the learning procedure, the safety devices are disabled!
Therefore any transit must be avoided in the leaf movement area when this operation is carried out.

Make sure the travel limit mechanical stops are present.

Opening/closing time is established by a learning procedure which varies slightly according to whether you are using limit-switches and/or Gatecoders.

6.3.1. LEARNING OF NORMAL TIMES

Normal learning (i.e. without limit-switches and Gatecoders) can be done in two different ways:

- **SIMPLE LEARNING (without deceleration):**

Check if the leaves are closed, enter "BASIC PROGRAMMING", select the TIME LEARNING function and press the + push-button for 1 second: the display begins flashing and the leaves begin the opening movement.

As soon as the leaves reach the opening contact point, give an OPEN A pulse (with the key operated push-button or with the radio control) to stop the movement: the leaves stop and the display stops flashing.

Press push-button F to exit and save the programming.

The procedure has ended and the gate is ready to operate.

- **COMPLETE LEARNING (with deceleration):**

Check if the leaves are closed, enter "BASIC PROGRAMMING", select the TIME LEARNING function and press the + push-button for more than 3 seconds: the display begins flashing and leaf 1 begins the opening movement. The following functions can be commanded by the OPEN A pulses (by key push-button or radio control):

- 1° OPEN - Deceleration at opening of leaf 1
- 2° OPEN - Leaf 1 stops at opening and leaf 2 begins its opening movement
- 3° OPEN - Deceleration at opening of leaf 2
- 4° OPEN - Leaf 2 stops at opening and immediately begins its closing movement
- 5° OPEN - Deceleration at closing of leaf 2
- 6° OPEN - Leaf 2 stops at closing and leaf 1 begins its closing movement
- 7° OPEN - Deceleration at closing of leaf 1
- 8° OPEN - Leaf 1 stops at closing

The display stops flashing: press push-button F to exit and save the programming.

The procedure has finished and the gate is ready to operate.

Notes: • If you wish to eliminate deceleration in certain stages, wait for the leaf to reach its stop-limit and supply 2 consecutive Open pulses (by 1 second).

• If only one leaf is present, the entire sequence must nevertheless be effected. When the leaf has finished opening, supply 5 Open pulses until the leaf begins to close, and then resume normal operation.

6.3.2. LEARNING WITH LIMIT-SWITCHES

Learning with limit-switches can be done in two different ways:

- **SIMPLE LEARNING (without deceleration):**

Check if the leaves are closed, enter "BASIC PROGRAMMING", select the TIME LEARNING function and press the + push-button for 1 second: the display begins flashing and the leaves begin the opening movement.

The motors stop automatically when the opening limit-switches are reached, but an OPEN A pulse must be given (by radio control or key push-button) to end the cycle.

The display stops flashing: press push-button F to exit and save the programming.

The procedure has finished and the gate is ready to operate.

- **COMPLETE LEARNING (with deceleration):**

Check if the leaves are closed, enter "BASIC PROGRAMMING", select the TIME LEARNING function and press the + push-button for more than 3 seconds: the display begins flashing and leaf 1 begins the opening movement.

The leaves automatically decelerate when they reach the limit-switches, and therefore, it is sufficient to inform the equipment that the stop limits have been reached by means of OPEN A pulses (by radio control or key push-button):

- FCA1 - Deceleration at opening of leaf 1
- 1° OPEN - Leaf 1 stops at opening and leaf 2 begins its opening movement
- FCA2 - Deceleration at opening of leaf 2
- 2° OPEN - Leaf 2 stops at opening and immediately begins its closing movement
- FCC2 - Deceleration at closing of leaf 2
- 3° OPEN - Leaf 2 stops at closing and leaf 1 begins its closing movement
- FCC1 - Deceleration at closing of leaf 1
- 4° OPEN - Leaf 1 stops at closing

The display stops flashing: press push-button F to exit and save the programming.

The procedure has finished and the gate is ready to operate

- Notes:**
- If you wish to eliminate deceleration in some stages, you must supply an Open pulse within 1 second of reaching the limit-switch.
 - If some limit-switches are not installed, start the corresponding deceleration by supplying an Open pulse (which replaces the limit-switch).
 - If only one leaf is present, the entire sequence must nevertheless be effected. When the leaf has finished opening, supply 5 Open pulses until the leaf begins to close, and then resume normal operation.

6.3.3. LEARNING TIMES WITH GATECODER

Learning with the Gatecoder can be done in two different ways:

- SIMPLE LEARNING (with deceleration):

Check if the leaves are closed, enter "BASIC PROGRAMMING", select the TIME LEARNING function and press the + push-button for 1 second: the display begins flashing and the leaves begin the opening movement.

The movement stops automatically when the opening stop limit is reached and the display stops flashing.

Press push-button F to exit and save the programming.

The procedure has ended and the gate is ready to operate, using fixed deceleration.

- COMPLETE LEARNING (with deceleration):

Check if the leaves are closed, enter "BASIC PROGRAMMING", select the TIME LEARNING function and press the + push-button for more than 3 seconds: the display begins flashing and leaf 1 begins the opening movement. The following functions can be commanded by the OPEN A pulses (by radio control or key push-button):

- 1° OPEN - Leaf 1 Decelerates at opening (it stops automatically on reaching the stop limit)
- 2° OPEN - Leaf 2 opening movement begins
- 3° OPEN - Leaf 2 Decelerates at opening (it stops automatically on reaching the stop limit)
- 4° OPEN - Leaf 2 closing movement begins
- 5° OPEN - Leaf 2 decelerates at closing (it stops automatically on reaching the stop limit)
- 6° OPEN - Leaf 1 closing movement begins
- 7° OPEN - Leaf 1 Decelerates at closing (it stops automatically on reaching the stop limit)
- 8° OPEN - End of learning

The display stops flashing: press push-button F to exit and save the programming.

The procedure has finished and the gate is ready to operate.

- Notes:**
- The deceleration pulse should be supplied a little earlier with respect to the stop limit to prevent the leaf reaching it at full speed (it would be taken for an obstacle).
 - If only one leaf is present, the entire sequence must nevertheless be effected. When the leaf has finished opening, supply 5 Open pulses until the leaf begins to close, and then resume normal operation.

6.3.4. LEARNING TIMES WITH GATECODER + LIMIT-SWITCH

Learning with Gatecoder + Limit-switch can be done in two different ways:

- SIMPLE LEARNING (without deceleration):

Check if the leaves are closed, and then access "BASIC PROGRAMMING", select the TIME LEARNING function and press push-button + for 1 second: the display starts to flash and the leaves begin the opening movement.

The motors stop automatically when the opening limit-switches are reached, and the display stops flashing. Press push-button F to exit and save the programming.

The procedure has finished and the gate is ready to operate. The Gatecoder is used solely as an obstacle sensor.

- COMPLETE LEARNING (with deceleration):

Check if the leaves are closed, and then access "BASIC PROGRAMMING", select the TIME LEARNING function and press push-button + for more than 3 seconds: the display starts to flash and the leaf 1 begins the opening movement. The leaves automatically slow down on reaching the limit-switches, and you can command the following functions with the OPEN A pulses (from a radio control or from a key operated push-button):

- FCA1 - Deceleration at opening of leaf 1 (stops automatically when it reaches the end contact point)
- 1st OPEN - Opening movement of leaf 2 begins
- FCA2 - Deceleration at opening of leaf 2 (stops automatically when it reaches the end contact point)
- 2nd OPEN - Closing movement of leaf 2 begins
- FCC2 - Deceleration at closing of leaf 2 (stops automatically when it reaches the end contact point)
- 3rd OPEN - Closing movement of leaf 1 begins
- FCC1 - Deceleration at closing of leaf 1 (stops automatically when it reaches the end contact point)
- 4th OPEN - End of learning

The display stops flashing: press push-button F to exit and save the programming.

The procedure has finished and the gate is ready for normal operation.

- Note:**
- If some limit-switches are not installed, start the corresponding deceleration by supplying an Open pulse (which replaces the limit-switch).
 - If only one leaf is present, the entire sequence must nevertheless be effected. When the leaf has finished opening, supply 5 Open pulses until the leaf begins to close, and then resume normal operation.

7. AUTOMATED SYSTEM TEST

When you have finished programming, check if the system is operating correctly.

Most important of all, check if the force is adequately adjusted and if the safety devices are operating correctly.

Tab. 3/a

Logic "E"		PULSES				
GATE STATUS	OPEN -A	OPEN -B	STOP	OPENING SAFETY DEVICES	CLOSING SAFETY DEVICES	OP/CL SAFETY DEVICE
CLOSED	Opens the leaf	Opens single leaf		No effect (OPEN disabled)	No effect	No effect (OPEN disabled)
OPEN	Re-closes the leaf immediately (3)			No effect (if on part.opng. OPEN A disabled)	No effect (3) (OPEN disabled)	No effect (OPEN disabled)
CLOSING	Re-opens the leaf immediately		Stops operation	No effect (saves OPEN)	see paragraph 5.2.	Locks and, on release, reverses to open
OPENING	Stops operation (3)			Reverses to close	No effect	Locks and, on release, continues opening
LOCKED	Closes the leaf (with Closing safety devices engaged, opens at the 2nd pulse) (3)		No effect (OPEN disabled)	No effect	No effect	No effect (OPEN disabled)

Tab. 3/b

Logic "A"		PULSES				
GATE STATUS	OPEN -A	OPEN -B	STOP	OPENING SAFETY DEVICES	CLOSING SAFETY DEVICES	OP/CL SAFETY DEVICE
CLOSED	Opens the leaf and closes it after pause time (1)	Opens single leaf and closes after pause time (1)		No effect (OPEN disabled)	No effect	No effect (OPEN disabled)
OPEN on PAUSE	Reloads pause time (1)(3)			No effect (if on part.opng. OPEN A disabled)	Reloads pause time (1) (3)	Reloads pause time (1) (OPEN disabled)
CLOSING	Re-opens the leaf immediately (1)		Stops operation	No effect (saves OPEN)	see paragraph 5.2.	Locks and, on release, reverses to open
OPENING	No effect (1) (3)			Reverses to close	No effect	Locks and, on release, continues opening
LOCKED	Closes the leaf (3)		No effect (OPEN disabled)	No effect	No effect	No effect (OPEN disabled)

Tab. 3/c

Logic "S"		PULSES				
GATE STATUS	OPEN -A	OPEN -B	STOP	OPENING SAFETY DEVICES	CLOSING SAFETY DEVICES	OP/CL SAFETY DEVICE
CLOSED	Opens the leaf and closes it after pause time	Opens single leaf and closes after pause time		No effect (OPEN disabled)	No effect	No effect (OPEN disabled)
OPEN on PAUSE	Re-closes the leaf immediately (3)			No effect (if on part.opng. OPEN A disabled)	On release, closes after 5" (OPEN disabled) (3)	On release, closes after 5" (OPEN disabled)
CLOSING	Re-opens the leaf immediately		Stops operation	No effect (saves OPEN)	see paragraph 5.2.	Locks and, on release, reverses to open
OPENING	Re-closes the leaf immediately (3)			Reverses to close	No effect (saves OPEN)	Locks and, on release, continues opening
LOCKED	Closes the leaf (3)		No effect (OPEN disabled)	No effect	No effect	No effect (OPEN disabled)

Tab. 3/d

Logic "EP"		PULSES				
GATE STATUS	OPEN -A	OPEN -B	STOP	OPENING SAFETY DEVICES	CLOSING SAFETY DEVICES	OP/CL SAFETY DEVICE
CLOSED	Opens the leaf	Opens leaf for the partial opening time		No effect (OPEN disabled)	No effect	No effect (OPEN disabled)
OPEN	Re-closes the leaf immediately (3)			No effect (if on part.opng. OPEN A disabled)	No effect (OPEN disabled) (3)	No effect (OPEN disabled)
CLOSING	Stops operation	Stops operation	Stops operation	No effect (saves OPEN)	see paragraph 5.2.	Locks and, on release, reverses to open
OPENING	Stops operation (3)	Stops operation (3)		see paragraph 5.2.	No effect	Locks and, on release, continues opening
LOCKED	Restarts movement in reverse direction (3) (always closes after a Stop)		No effect (OPEN disabled)	No effect (if it must open, it disables OPEN)	No effect (if it must close, it disables OPEN)	No effect (OPEN disabled)

- (1) If maintained, it prolongs the pause until disabled by the command (timer function)
 (2) If a new pulse occurs within 2 seconds after reversing, it immediately stops operation.
 (3) During the partial opening cycle, an OPEN A pulse causes total opening.
 NB.: Effects on other active pulse inputs in brackets.

Tab. 3/e

PULSES						
Logic "A"	OPEN-A	OPEN-B	STOP	OPENING SAFETY DEVICES	CLOSING SAFETY DEVICES	OP/CL SAFETY DEVICE
GATE STATUS						
CLOSED	Opens the leaf and closes it after pause time	Opens single leaf and closes after pause time		No effect (OPEN disabled)	No effect	No effect (OPEN disabled)
OPEN on PAUSE	Stops operation (3)	Stops operation (3)	Stops operation	No effect (if on part.opng. OPEN A disabled)	Reloads pause time (3) (OPEN disabled)	Reloads pause time (OPEN disabled)
CLOSING	Re-opens the leaf immediately			No effect (saves OPEN)	see paragraph 5.2.	Locks and, on release, reverses to open
OPENING	Stops operation (3)	Stops operation (3)		Reverses to close	No effect	Locks and, on release, continues opening
LOCKED	Closes the leaf (with Closing Safety devices engaged, opens at the 2nd pulse) (3)		No effect (OPEN disabled)	No effect	No effect	No effect (OPEN disabled)

Tab. 3/f

PULSES						
Logic "SP"	OPEN-A	OPEN-B	STOP	OPENING SAFETY DEVICES	CLOSING SAFETY DEVICES	OP/CL SAFETY DEVICE
GATE STATUS						
CLOSED	Opens the leaf and closes it after pause time	Opens single leaf and closes after pause time		No effect (OPEN disabled)	No effect	No effect (OPEN disabled)
OPEN on PAUSE	Stops operation (3)	Stops operation (3)	Stops operation	No effect (if on part.opng. OPEN A disabled)	On release, closes after 5" (OPEN disabled)	On release, closes after 5" (OPEN disabled)
CLOSING	Re-opens the leaf immediately			No effect (saves OPEN)	see paragraph 5.2.	Locks and, on release, reverses to open
OPENING	Stops operation (3)	Stops operation (3)		Reverses to close	No effect (saves OPEN)	Locks and, on release, continues opening
LOCKED	Closes the leaf (3)		No effect (OPEN disabled)	No effect	No effect	No effect (OPEN disabled)

Tab. 3/g

PULSES						
Logic "B"	OPEN-A (opening)	OPEN-B (closing)	STOP	OPENING SAFETY DEVICES	CLOSING SAFETY DEVICES	OP/CL SAFETY DEVICE
GATE STATUS						
CLOSED	Opens the leaf	No effect		No effect (OPEN A disabled)	No effect	No effect (OPEN A disabled)
OPEN	No effect	Closes the leaf	No effect (OPEN B disabled)	No effect	No effect (OPEN B disabled)	No effect (OPEN B disabled)
CLOSING	Reverses to open	No effect	Stops operation	No effect (saves OPEN A)	Stops operation (OPEN-B disabled)	Stops operation (OPEN-A/B disabled)
OPENING	No effect	No effect		Stops operation (OPEN-A disabled)	No effect	
LOCKED	Opens the leaf	Closes the leaf	No effect (OPEN A/B disabled)	No effect (OPEN-A disabled)	No effect (OPEN B disabled)	No effect (OPEN A/B disabled)

Tab. 3/h

CONTROLS ALWAYS HELD DOWN						
Logic "C"	OPEN-A (opening)	OPEN-B (closing)	STOP	OPENING SAFETY DEVICES	CLOSING SAFETY DEVICES	OP/CL SAFETY DEVICE
GATE STATUS						
CLOSED	Opens the leaf	No effect (OPEN-A disabled)		No effect (OPEN A disabled)	No effect	No effect (OPEN A disabled)
OPEN	No effect (OPEN-B disabled)	Closes the leaf	No effect (OPEN-A/B disabled)	No effect (OPEN A disabled)	No effect (OPEN B disabled)	No effect (OPEN B disabled)
CLOSING	Stops operation	/	Stops operation	No effect	Stops operation (OPEN-B disabled)	Stops operation (OPEN-A/B disabled)
OPENING	/	Stops operation		Stops operation (OPEN-A disabled)	No effect	

- (1) If maintained, it prolongs the pause until disabled by the command (timer function)
- (2) If a new pulse occurs within 2 seconds after reversing, it immediately stops operation.
- (3) During the partial opening cycle, an OPEN A pulse causes total opening.

NB.: Effects on other active pulse inputs in brackets.