

CE DECLARATION OF CONFORMITY

Manufacturer: FAAC S.p.A.

Address: Via Benini, 1 - 40069 Zola Predosa BOLOGNA - ITALY

Declares that: 452 MPS control board,

- conforms to the essential safety requirements of the following directives:

2006/95/EC Low Voltage Directive

2004/108/EC Electromagnetic Compatibility Directive

Additional note:

This product underwent tests in a typical uniform configuration (all products manufactured by FAAC S.p.A.).

Bologna, 01 September 2008

The Managing Director
A. Marcellan



WARNINGS FOR THE INSTALLER

GENERAL SAFETY OBLIGATIONS

- 1) **ATTENTION! To ensure the safety of people, it is important that you read all the following instructions. Incorrect installation or incorrect use of the product could cause serious harm to people.**
- 2) Carefully read the instructions before beginning to install the product.
- 3) Do not leave packing materials (plastic, polystyrene, etc.) within reach of children as such materials are potential sources of danger.
- 4) Store these instructions for future reference.
- 5) This product was designed and built strictly for the use indicated in this documentation. Any other use, not expressly indicated here, could compromise the good condition/operation of the product and/or be a source of danger.
- 6) FAAC declines all liability caused by improper use or use other than that for which the automated system was intended.
- 7) Do not install the equipment in an explosive atmosphere: the presence of inflammable gas or fumes is a serious danger to safety.
- 8) The mechanical parts must conform to the provisions of Standards EN 12604 and EN 12605.
For non-EU countries, to obtain an adequate level of safety, the Standards mentioned above must be observed, in addition to national legal regulations.
- 9) FAAC is not responsible for failure to observe Good Technique in the construction of the closing elements to be motorised, or for any deformation that may occur during use.
- 10) The installation must conform to Standards EN 12453 and EN 12445.
For non-EU countries, to obtain an adequate level of safety, the Standards mentioned above must be observed, in addition to national legal regulations.
- 11) Before attempting any job on the system, cut out electrical power .
- 12) The mains power supply of the automated system must be fitted with an all-pole switch with contact opening distance of 3mm or greater. Use of a 6A thermal breaker with all-pole circuit break is recommended.
- 13) Make sure that a differential switch with threshold of 0.03 A is fitted upstream of the system.
- 14) Make sure that the earthing system is perfectly constructed, and connect metal parts of the means of the closure to it.
- 15) The safety devices (EN 12978 standard) protect any danger areas against **mechanical movement Risks**, such as crushing, dragging, and shearing.
- 16) Use of at least one indicator-light (e.g. FAACLIGHT) is recommended for every system, as well as a warning sign adequately secured to the frame structure, in addition to the devices mentioned at point "15".
- 17) FAAC declines all liability as concerns safety and efficient operation of the automated system, if system components not produced by FAAC are used.
- 18) For maintenance, strictly use original parts by FAAC.
- 19) Do not in any way modify the components of the automated system.
- 20) The installer shall supply all information concerning manual operation of the system in case of an emergency, and shall hand over to the user the warnings handbook supplied with the product.
- 21) Do not allow children or adults to stay near the product while it is operating.
- 22) Keep remote controls or other pulse generators away from children, to prevent the automated system from being activated involuntarily.
- 23) Transit is permitted only when the automated system is idle.
- 24) The user must not attempt any kind of repair or direct action whatever and contact qualified personnel only.
- 25) Maintenance: check at least every 6 months the efficiency of the system, particularly the efficiency of the safety devices (including, where foreseen, the operator thrust force) and of the release devices.
- 26) **Anything not expressly specified in these instructions is not permitted.**

CONTROL BOARD 452 MPS

1. WARNINGS

Important: Before attempting any work on the control board (connections, maintenance), always turn off power.

- Install, upstream of the system, a differential thermal breaker with adequate tripping threshold.
- Connect the earth cable to the appropriate terminal on the J3 connector of the equipment (see fig.2).
- Always separate power cables from control and safety cables (push-button, receiver, photocells, etc.). To avoid any electric noise, use separate sheaths or a shielded cable (with earthed shield).

2. TECHNICAL SPECIFICATIONS

Power supply	230 V~ (+6% -10%) - 50 Hz
Absorbed power	10 W
Motor max. load	800 W
Accessories max. load	0,5 A
Electric lock max. load	15 VA
Operating ambient temperature	-20 °C +55 °C
Protection fuses	2 (see fig. 1)
Function logics	Automatic / Semi-automatic / "Stepped" Safety device / Semi-automatic B/ Dead-man C / "Stepped" semi automatic
Opening/closing time	Programmable (from 0 to 120 s)
Pause time	0, 10, 20, 30, 60, 120 s
Closing leaf delay	0, 5, 10, 20 s
Opening leaf delay	2 s (Can be disabled with the clip-switch)
Thrust force	Dip-switch adjustable on 8 levels for each motor
Terminal board inputs	Open / Open free leaf / Stop / Opening safety devices / Closing safety devices / Power supply + Earth
Terminal board outputs	Flashing lamp - Motors - 24 Vdc accessories power supply - 24 Vdc indicator-light - Fail safe - 12 Vac electric lock power supply
Rapid connector	To connect MiniDec, Decoder or RP cards
Selectable functions	Logics and pause times - Thrust force - Opening and closing leaf delay - Reversing stroke - Fail safe - Closing safety devices logic - Pre-flashing
Programming key	work time learning

3. LAYOUT AND COMPONENTS OF 452 MPS

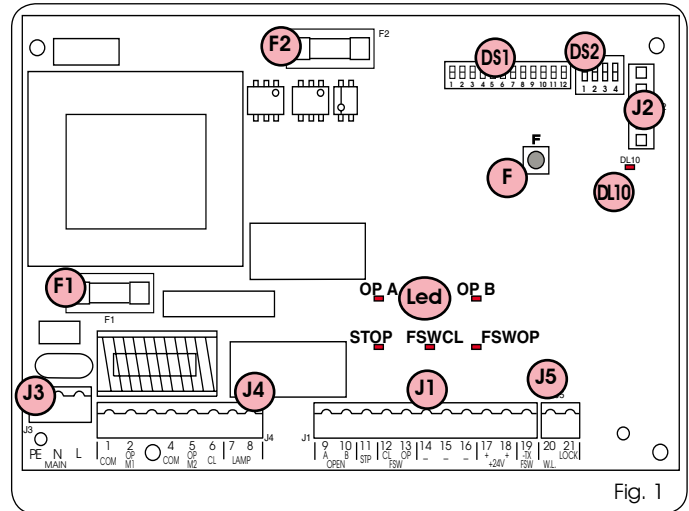
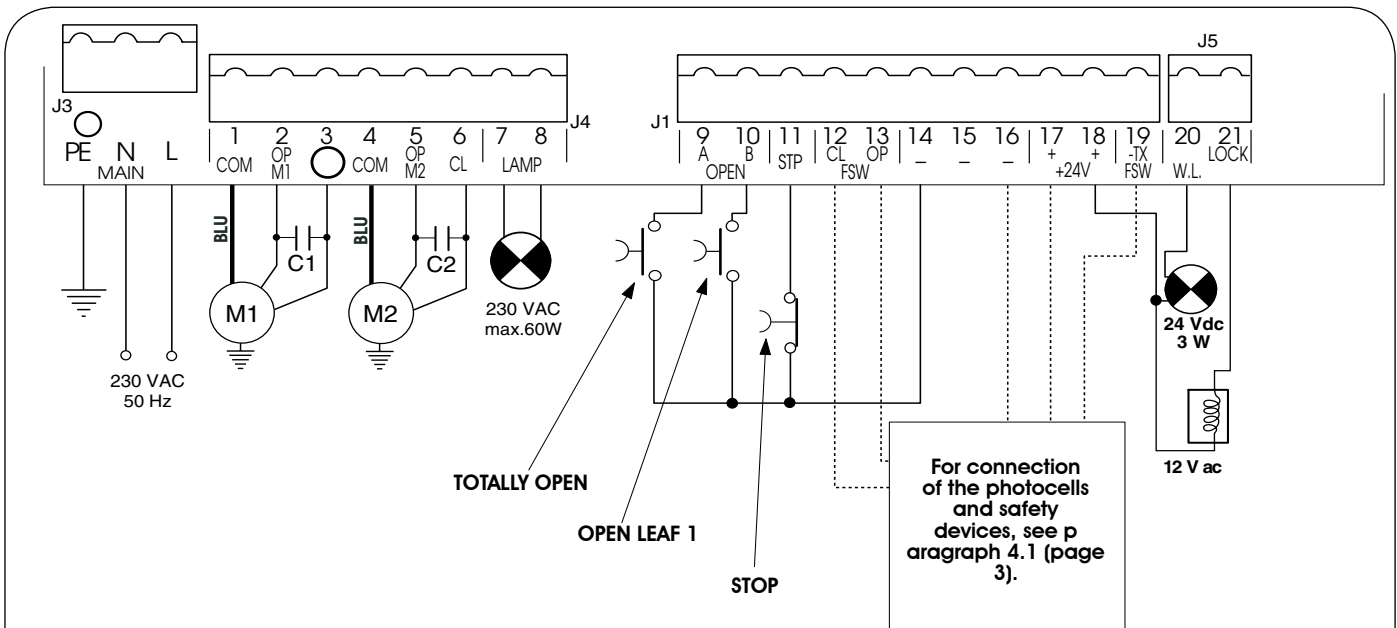

Fig. 1

Led OP_A	TOTALLY OPEN LED
Led OP_B	LED: OPEN LEAF 1 / CLOSE
Led STOP	LED STOP
Led FSWCL	LED: CLOSING SAFETY DEVICES
Led FSWOP	LED: OPENING SAFETY DEVICES
DL10	LED: TIME LEARNING SIGNALLING
J1	LOW VOLTAGE TERMINAL BOARD
J2	CONNECTOR FOR DECODER/MINIDEC/RP RECEIVER
J3	230 VAC POWER SUPPLY TERMINAL BOARD
J4	MOTORS AND FLASHING LAMP CONNECTION TERMINAL BOARD
J5	INDICATOR-LIGHT AND ELECTRIC LOCK CONNECTION TERMINAL BOARD
F1	MOTORS AND TRANSFORMER PRIMARY WINDING FUSE (I 5A)
F2	LOW VOLTAGE AND ACCESSORIES FUSE (I 800mA)
F	TIME LEARNING PUSH-BUTTON
DS1	1ST GROUP OF MICROSWITCH PROGRAMMING
DS2	2ND GROUP OF MICROSWITCH PROGRAMMING

4. ELECTRIC CONNECTIONS



NB.: Capacitors are supplied with the operators.

Fig. 2

4.1. Connection of photocells and safety devices

Before connecting the photocells (or other devices) we advise you to select the type of operation according to the movement area they have to protect (see fig.3):

Opening safety devices: they operate only during the gate opening movement and, therefore, they are suitable for protecting the area between the opening leaves and fixed obstacles (walls, etc) against the risk of impact and crushing.

Closing safety devices: they operate only during the gate closing movement and, therefore, they are suitable for protecting the closing area against the risk of impact.

Opening/closing safety devices: they operate during the gate

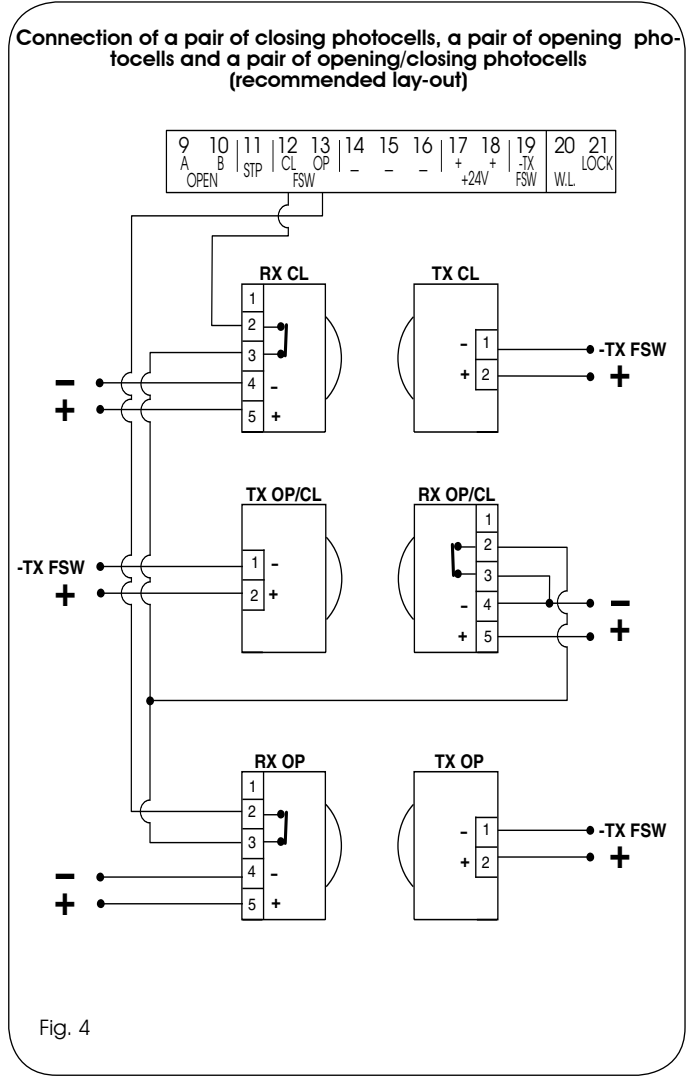
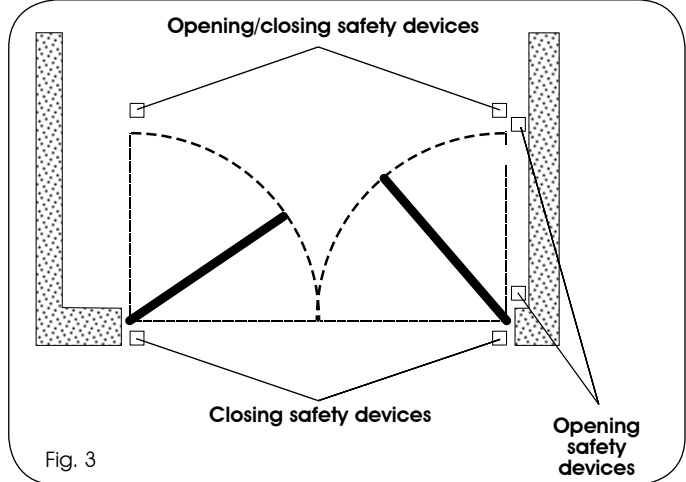

opening and closing movements and, therefore, they are suitable for the opening and closing areas against the risk of impact.

FAAC recommends use of the lay-out in fig. 4 (in the event of fixed obstacles at opening) or in fig. 5 (no fixed obstacles).

If two or more devices have the same function (opening or closing), they should be connected to each other in series (see fig. 12). N.C. contacts must be used.

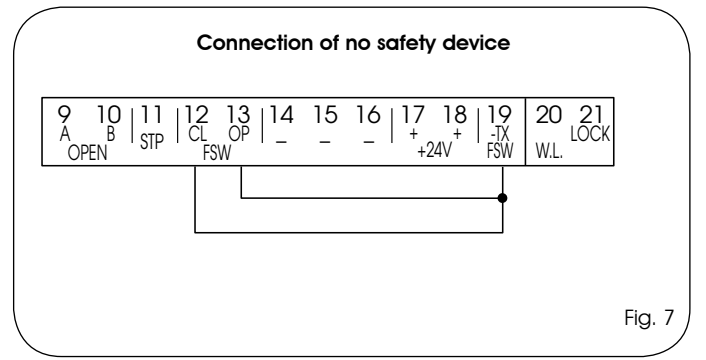
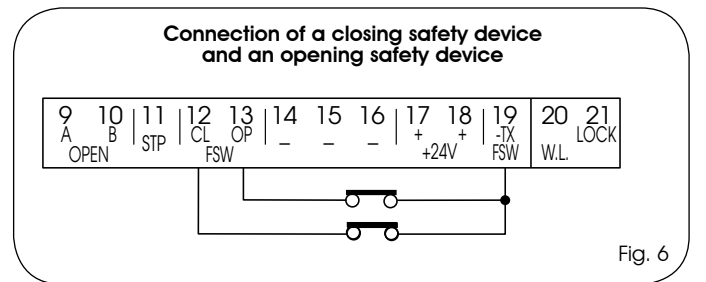
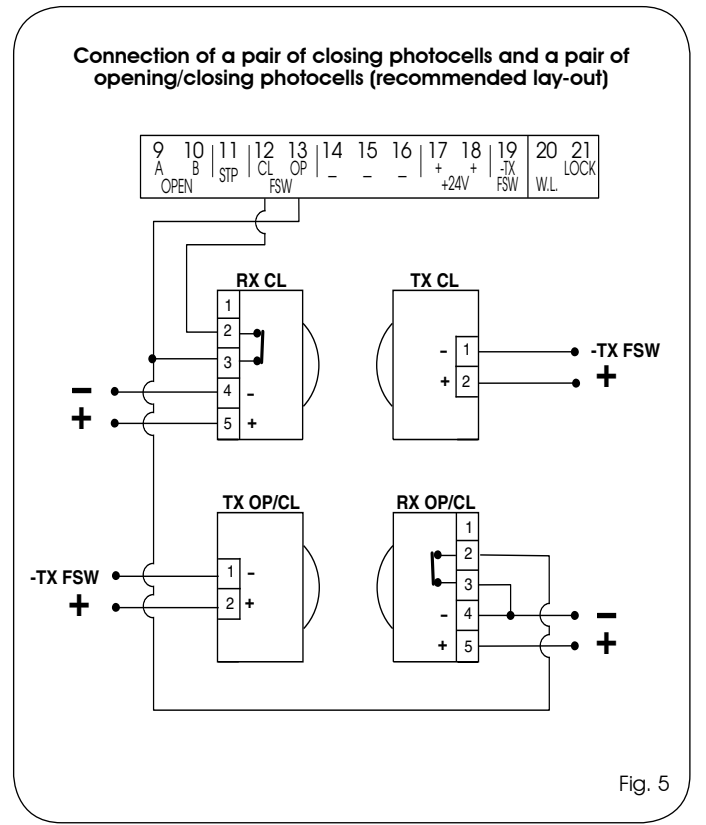

ENGLISH

Connection of 1 pair of opening photocells

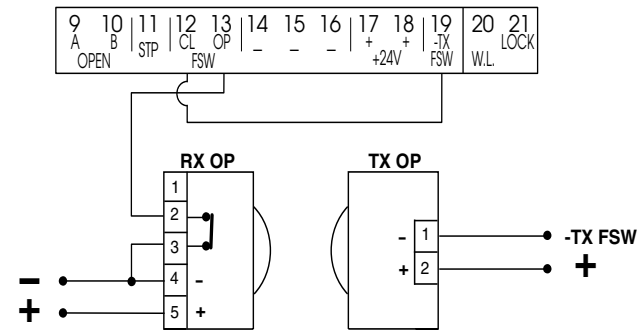

Fig. 8

Connection of two pairs of closing photocells

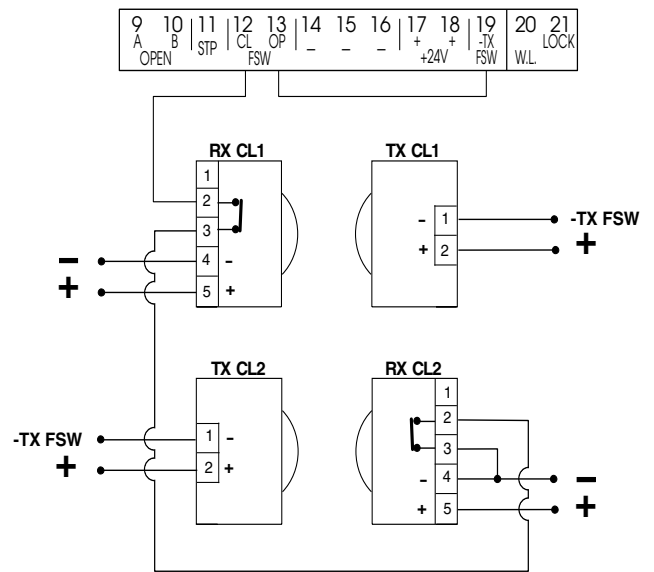

Fig. 11

Connection of 1 pair of closing photocells

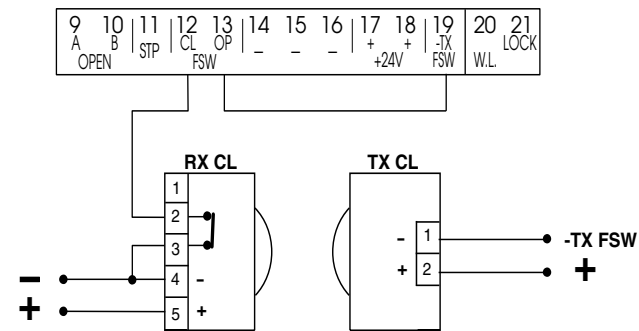

Fig. 9

Connection of 2 N.C. contacts in series
(e.g. Photocells, Stop)



Fig. 12

Connection of a pair of opening photocells
and a pair of closing photocells

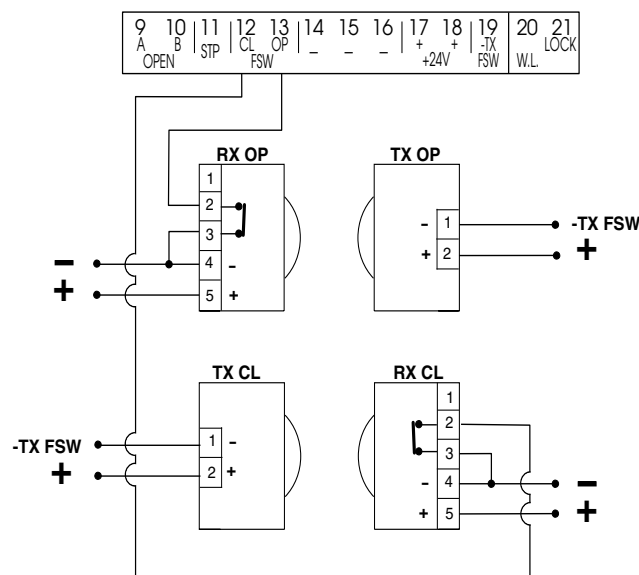

Fig. 10

Connection of 2 N.O. contacts in parallel
(e.g. Open A, Open B)

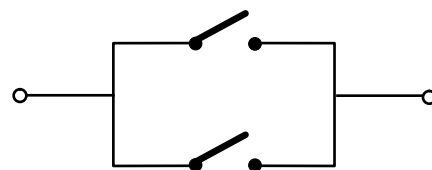

Fig. 13

4.2. Terminal board J3 - Power supply (fig. 2)

- PE : Earth connection
- N : 230 V~ power supply (Neutral)
- L : 230 V~ power supply (Line)



For correct operation, the board must be connected to the earth conductor in the system. Install an adequate differential thermal breaker upstream of the system.

4.3. Terminal board J4 - Motors and flashing lamp (fig. 2)

- M1 : COM / OP / CL: Connection to Motor 1
Can be used in the single-leaf application
- M2 : COM / OP / CL: Connection to Motor 2
Cannot be used in the single-leaf application
- LAMP : Flashing lamp output (230 V ~)

4.4. Terminal board J1 - Accessories (fig. 2)

OPEN A - "Total Opening" command (N.O.): any pulse generator (push-button, detector, etc.) which, by closing a contact, commands opening and/or closing of both gate leaves.
To install several full opening pulse generators, connect the N.O. contacts in parallel (see fig. 13).

OPEN B - "Partial Opening" command (N.O.) / Closing: any pulse generator (push-button, detector, etc.) which, by closing a contact, commands opening and/or closing of the leaf driven by motor M1. In the **B** and **C** logics, it always commands closing of both leaves.
To install several partial opening pulse generators, connect the N.O. contacts in parallel (see fig. 13).

STP - STOP Contact (N.C.): any device (e.g. a push-button) which, by opening a contact, is able to stop gate movement.
To install several STOP devices, connect the N.C. contacts in series (see fig. 12).

 **If STOP devices are not connected, jumper connect the STP terminals and -.**

CL FSW - Closing safety devices contact (N.C.):
The purpose of the closing safety devices is to protect the leaf movement area during closing. During closing, in the **A-SP-E-EP** logics, the safety devices reverse the movement of the gate leaves, or stop and reverse the movement when they are released (see programming of microswitch **DS2 - SW2**). During the closing cycle in logics **B** and **C**, they interrupt movement. They never operate during the opening cycle. If the **closing safety devices** operate when the gate is open, they prevent the leaf closing movement.

 **If no closing safety devices are connected, jumper connect terminals CL and -TX FSW (fig. 7).**

OP FSW - Opening safety devices contact (N.C.):
the purpose of the opening safety devices is to protect the leaf movement area during opening. During opening, in the **A-SP-E-EP** logics, the safety devices stop the movement of the gate leaves and reverse the movement when they are released. During the opening cycle in logics **B** and **C**, they interrupt movement. They never operate during the closing cycle.
If the **opening safety devices** operate when the gate is closed, they prevent the leaf opening movement.

 **If no opening safety devices are connected, jumper connect inputs OP and -TX FSW (fig. 7)**

-- Negative for power supply to accessories

± 24 Vdc - Positive for power supply to accessories

 **Accessories max. load is 500 mA. To calculate absorption values, refer to the instructions for individual accessories.**

-TX FSW - Negative for power supply to photocell transmitters

If you use this terminal for connecting the negative for supplying power to the photocell transmitters, you may, if necessary, also use the FAIL SAFE function (see programming of microswitch **DS2 - SW3**).
If this function is enabled, the equipment checks operation of the photocells before every opening or closing cycle.

4.5. Terminal board J5 - Indicator-light and Electric lock (fig.2)

W.L. - Power supply to indicator-light
Connect a 24 Vdc - 3 W max. indicator-light, if necessary, between this terminal and the +24V supply. To avoid compromising correct operation of the system, **do not exceed** the indicated power.

LOCK - Power supply to electric lock

If necessary, connect a 12 V ac electric lock between this terminal and the +24V supply.

4.6. Connector J2 - Rapid connection (fig.2)

This is used for rapid connection of Minidec, Decoder and RP receivers (see fig. 14, 15, 16 and 17). Connect the accessory, with the components side facing the inside of the card. Insert and remove after cutting power.

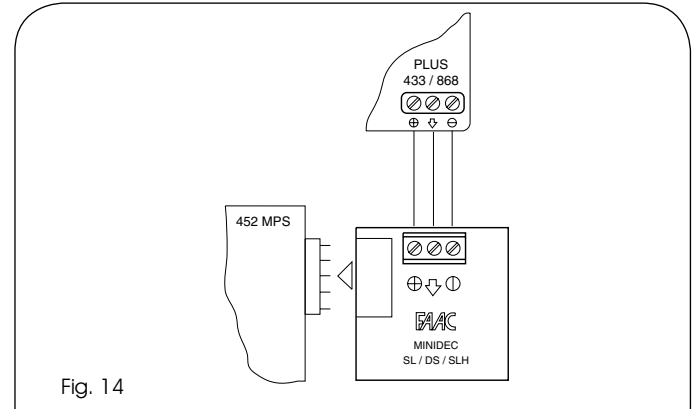

Fig. 14

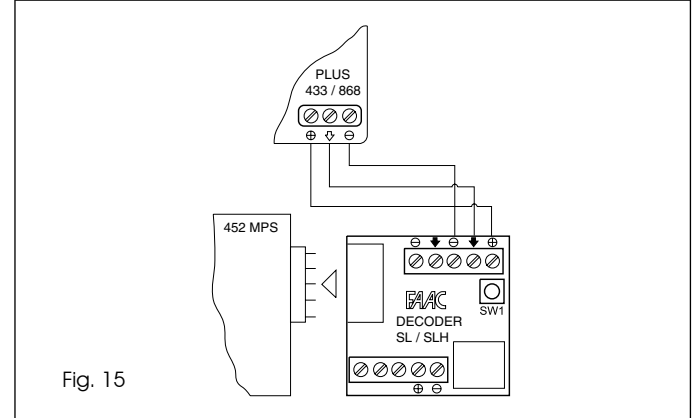

Fig. 15

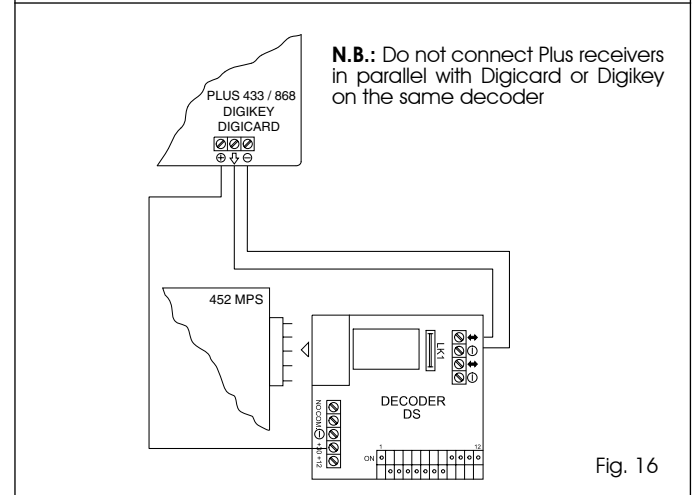

Fig. 16

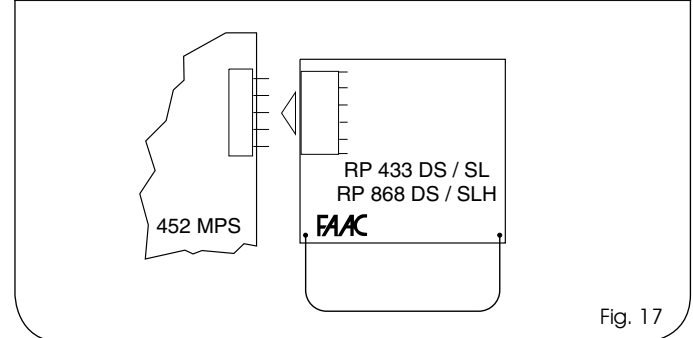

Fig. 17

ENGLISH

5. MICROSWITCH PROGRAMMING

LEAF 1 FORCE	SW1	SW2	SW3	LEAF 2 FORCE	SW4	SW5	SW6
1 (MIN)	ON	ON	ON	1 (MIN)	ON	ON	ON
2	OFF	ON	ON	2	OFF	ON	ON
3	ON	OFF	ON	3	ON	OFF	ON
4	OFF	OFF	ON	4	OFF	OFF	ON
5	ON	ON	OFF	5	ON	ON	OFF
6	OFF	ON	OFF	6	OFF	ON	OFF
7	ON	OFF	OFF	7	ON	OFF	OFF
8 (MAX)	OFF	OFF	OFF	8 (MAX)	OFF	OFF	OFF



LOGIC	PAUSE (s)	SW7	SW8	SW9	SW10
E	/	ON	ON	ON	ON
EP	/	OFF	ON	ON	ON
B	/	ON	OFF	ON	ON
C	/	OFF	OFF	ON	ON
A	0	ON	ON	OFF	ON
A	10	OFF	ON	OFF	ON
A	20	ON	OFF	OFF	ON
A	30	OFF	OFF	OFF	ON
A	60	ON	ON	ON	OFF
A	120	OFF	ON	ON	OFF
SP	0	ON	OFF	ON	OFF
SP	10	OFF	OFF	ON	OFF
SP	20	ON	ON	OFF	OFF
SP	30	OFF	ON	OFF	OFF
SP	60	ON	OFF	OFF	OFF
SP	120	OFF	OFF	OFF	OFF

CLOSING LEAF DELAY (s)	SW11	SW12
20	ON	ON
10	OFF	ON
5	ON	OFF
0	OFF	OFF

DS1

Fig. 18a

OPENING LEAF DELAY (s)	SW1
2	ON
0	OFF

CLOSING PHOTOCELL LOGIC	SW2
REVERSES ON RELEASE	ON
REVERSES IMMEDIATELY	OFF

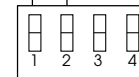

FAIL SAFE	SW3
YES	ON
NO	OFF

REVERSING STROKE	SW4
YES	ON
NO	OFF

DS2

Fig. 18b

5.1. MICROSWITCHES DS1 (fig. 18a)

Leaf 1 and 2 force

By using microswitches SW1, SW2 and SW3, the force (and thus anti-crushing safety) of the operator connected to leaf 1 can be programmed. The same operation has to be repeated on the motor connected to leaf 2, by using microswitches SW4, SW5 and SW6.

As concerns the hydraulic operators, select maximum force (level 8) on the equipment and adjust thrust with the operator by-pass valves.

Function logic

The automated system's function logic can be selected with microswitches SW7, SW8, SW9 and SW10. By selecting an automatic logic (A, SP), the combination of microswitches enables selection of pause time too (waiting time, in opening position, before automatic re-closing). The available logics - their operation is described in tables 3/a-b-c-d-e-f, are as follows: A - SP (Automatic), E - EP - B (Semi-automatic), C (Dead-man).

Closing leaf delay

Programming of microswitches SW11 and SW12 enables delay of the closing start of leaf 1 with respect to leaf 2, in order to avoid the leaves overlapping during movement, and thus increase the safety of the system.

5.2. MICROSWITCHES DS2 (fig.18b)

Opening leaf delay

Programming of microswitch SW1 enables delay of the opening start of leaf 2 with respect to leaf 1, in order to avoid the leaves obstructing each other during the initial stage of movement.

Closing photocells logic

By using microswitch SW2, you can select the type of behaviour of the automated system if the photocells protecting the gate closing movement are engaged. You can obtain either immediate reversing of the leaves or a stop followed by reversing when the photocells are disengaged.

Fail safe

Programming the microswitch SW3 makes it possible to activate or deactivate the photocells control test. When Fail safe is active, the equipment checks the photocells before every opening or closing movement.

Reversing stroke

By using the microswitch SW4, you can activate the "reversing stroke". The "reversing stroke" pushes the leaves to close for a few moments before opening the gate, thus facilitating release of the electric lock.

6. START-UP

6.1. LED CHECK

The table below shows the status of the LEDs in relation to the status of the inputs.

Note the following: **LED LIGHTED** = closed contact

LED OFF = open contact

Check the state of the LEDs as per Table.

Operation of the status signalling LEDs

LEDs	LIGHTED	OFF
OP_A	Command activated	Command inactive
OP_B	Command activated	Command inactive
STOP	Command inactive	Command activated
FSWCL	Safety devices disengaged	Safety devices engaged
FSWOP	Safety devices disengaged	Safety devices engaged

 The status of the LEDs while the gate is at rest are shown in bold.

Furthermore, the DL10 LED is on the board and functions as detailed in the following table:

DL10		
Gate closed at rest: OFF	Gate moving or on pause: like indicator-light	Time learning: flashes rapidly

6.2. ROTATION DIRECTION AND FORCE CHECK

- 1) Program the microswitches of the control board according to need, as shown in Chapter 5.
- 2) Cut power to the electronic control equipment.
- 3) Release the operators and manually move the gate to the mid-point of the opening angle.
- 4) Re-lock the operators.
- 5) Restore power.
- 6) Send an opening command on the OPEN A input (fig.2) and check if the gate leaves are being commanded to open.

 open.

If the first OPEN A pulse commands a closing, cut power and change over the phases of the electric motor (brown and black wires) on the terminal board.

- 7) Check power setting of the motors and, if necessary, modify it (see Chapter 5.1).
- 8) Stop leaf movement with a STOP command.
- 9) Release the operators, close the leaves and re-lock the operators.

6.3. LEARNING OF OPERATING TIMES



during the learning procedure, the safety devices are disabled! Therefore any transit must be avoided in the leaf movement area when this operation is carried out.

Opening/closing time is established by a learning procedure which can be effected in two different ways depending on the type of system.

Simple learning makes it possible to effect a single rapid operation to supply work times to the board, without using deceleration. It is not recommended if the speeds of the leaves differ considerably from each other (different operators, different opening dimensions or angles).

Complete learning makes it possible to exploit all functions of the equipment, and thus program different work times for each leaf, and also opening and closing deceleration.

- SIMPLE LEARNING:

Check if the leaves are closed, and then press F push-button for one second: DL10 LED begins flashing and the leaves begin the opening movement.

Wait for the leaf to reach the opening stop limit and then supply an OPEN A pulse (with the radio control or with the key controlled push-button) to stop the movement: the leaves stop and the DL10 LED stops flashing.

The procedure has ended and the gate is ready to operate.

Next pulse closes leaves and they stop on automatically reaching closed position.

- ADVANCED COMPLETE LEARNING:

Check if the leaves are closed, and then press F push-button for more than 3 seconds: DL10 LED begins flashing and the leaf 1 begins the opening movement. The following functions can be commanded by the OPEN A pulses (by radio control or key controlled push-button):

- 1° OPEN - Deceleration at opening of leaf 1
- 2° OPEN - Leaf 1 stops at opening and leaf 2 begins its opening movement
- 3° OPEN - Deceleration at opening of leaf 2
- 4° OPEN - Leaf 2 stops at opening and immediately begins its closing movement
- 5° OPEN - Deceleration at closing of leaf 2
- 6° OPEN - Leaf 2 stops at closing and leaf 1 begins its closing movement
- 7° OPEN - Deceleration at closing of leaf 1
- 8° OPEN - Leaf 1 stops at closing

The DL10 LED stops flashing and the gate is ready for normal operation.

- Notes:**
- If you wish to eliminate deceleration in certain stages, wait for the leaf to reach its stop-limit and supply 2 consecutive Open pulses (by 1 second).
 - If only one leaf is present, the entire sequence must nevertheless be effected. When the leaf has finished opening, supply 5 Open pulses until the leaf begins to close, and then resume normal operation.
 - If wind effected areas it is best to allow 2 second after the leaf reaches open stop before supplying Open A to ensure full closing.
 - Use of slow-down is not recommended for condominium entries.
 - If, during closing / opening, the cycle stops for more consecutive times, the leaf could not reach the limit stop with slow-down. At the first complete cycle without interruptions, the system recognizes the limit stops and carries out again the programmed slow-downs.

6.4. PRE-FLASHING

If you wish to increase the equipment's safety level, you can activate the pre-flashing function which enables the flashing lamp to go on 5 seconds before the leaf starts to move.

Pre-flashing activation procedure:

- 1 - check if the gate is closed
- 2 - open and keep open the **Stop** contact
- 3 - check if the **DL10** LED is OFF (if lighted, pre-flashing is already active)
- 4 - briefly press the **F** push-button and check if the **DL10** LED lights up.
- 5 - close the **Stop** contact (DL10 goes OFF).

Procedure for disabling the function:

- 1 - check if the gate is closed
- 2 - open and keep open the **Stop** contact
- 3 - check if the **DL10** LED is lighted (if OFF, pre-flashing is already disabled)
- 4 - briefly press the **F** push-button and check if the **DL10** LED is OFF.
- 5 - close the **Stop** contact

7. AUTOMATED SYSTEM TEST

When you have finished programming, check if the system is operating correctly.

Most important of all, check if the force is adequately adjusted and if the safety devices are operating correctly.

Table 3/a

LOGIC "A"		PULSES					W.L.
GATE STATUS	OPEN-A	OPEN-B	STOP	OPENING SAFETY DEVICES	CLOSING SAFETY DEVICES	OP/CLOS. SAFETY DEVICE	W.L.
CLOSED	Opens leaves and closes them after pause time (1)	Opens the free leaf and closes after pause time (1)	No effect (OPEN disabled)	No effect (OPEN disabled)	No effect	No effect (OPEN disabled)	OFF
OPEN on PAUSE	Reloads pause time (1)	Reloads pause time (1)	Stops operation	No effect	Freezes pause until release (2) (OPEN disabled)	Locks and, on release, releases at opening	lighted
AT CLOSING	Re-opens the leaves immediately (1)	Re-opens the leaf immediately (1)		No effect (saves OPEN)	see paragraph 5.2.		
AT OPENING	No effect (1)	No effect (1)	No effect (OPEN disabled)	Reverses at closing	No effect	Locks and, on release, continues opening	lighted
LOCKED	Closes the leaf/leaves		No effect (OPEN disabled)	No effect	No effect (OPEN disabled)	No effect (OPEN disabled)	lighted

Table 3/b

LOGIC "SP"		PULSES					W.L.
GATE STATUS	OPEN-A	OPEN-B	STOP	OPENING SAFETY DEVICES	CLOSING SAFETY DEVICES	OP/CLOS. SAFETY DEVICE	W.L.
CLOSED	Opens leaves and closes them after pause time	Opens the free leaf and closes after pause time	No effect (OPEN disabled)	No effect (OPEN disabled)	No effect	No effect (OPEN disabled)	OFF
OPEN on PAUSE	Stops operation	Stops operation	Stops operation	No effect	Closes after 5' (OPEN disabled)	Locks and, on release, releases at opening	lighted
AT CLOSING	Re-opens the leaves immediately	Re-opens the leaf immediately		No effect (saves OPEN)	see paragraph 5.2.		
AT OPENING	Re-closes the leaves immediately	Re-closes the leaf immediately	No effect (OPEN disabled)	Reverses at closing	No effect	Locks and, on release, continues opening	lighted
LOCKED	Closes the leaf/leaves		No effect (OPEN disabled)	No effect	No effect (OPEN disabled)	No effect (OPEN disabled)	lighted

Table 3/c

LOGIC "E"		PULSES					W.L.
GATE STATUS	OPEN-A	OPEN-B	STOP	OPENING SAFETY DEVICES	CLOSING SAFETY DEVICES	OP/CLOS. SAFETY DEVICE	W.L.
CLOSED	Opens the leaves	Opens the free leaf	No effect (OPEN disabled)	No effect (OPEN disabled)	No effect	No effect (OPEN disabled)	OFF
OPEN	Re-closes the leaves immediately	Re-closes the leaf immediately	Stops operation	No effect	No effect (OPEN disabled)	Locks and, on release, releases at opening	lighted
AT CLOSING	Re-opens the leaves immediately	Re-opens the leaf immediately		No effect (saves OPEN)	see paragraph 5.2.		
AT OPENING	Stops operation	Stops operation	No effect (OPEN disabled)	Reverses at closing	No effect	Locks and, on release, continues opening	lighted
LOCKED	Closes the leaf/leaves (with CLOSING SAFETY DEVICES active, opens at 2nd pulse)		No effect (OPEN disabled)	No effect	No effect (OPEN disabled)	No effect (OPEN disabled)	lighted

Table 3/d

PULSES						
LOGIC "EP"	OPEN-A	OPEN-B	STOP	OPENING SAFETY DEVICES	CLOSING SAFETY DEVICES	W.L.
GATE STATUS						
CLOSED	Opens the leaves	Opens the rise leaf	No effect (OPEN disabled)	No effect (OPEN disabled)	No effect	OFF
OPEN	Re-closes the leaf/leaves immediately		Stops operation	No effect (OPEN disabled)	No effect (OPEN disabled)	lighted
AT CLOSING	Stops operation			No effect (saves OPEN)	see paragraph 5.2.	flashing
AT OPENING	Stops operation			Reverses at closing	No effect	lighted
LOCKED	Restarts moving in reverse direction (always closes after a Stop)		No effect (OPEN disabled)	No effect (if it must open, it disables OPEN)	No effect (OPEN disabled)	lighted

Table 3/e

PULSES						
LOGIC "B"	OPEN-A	OPEN-B	STOP	OPENING SAFETY DEVICES	CLOSING SAFETY DEVICES	W.L.
GATE STATUS						
CLOSED	Opens the leaf or leaves	No effect	No effect (OPEN-A disabled)	No effect (OPEN-A disabled)	No effect (OPEN-B disabled)	OFF
OPEN	No effect	Closes the leaves or leaf	No effect (OPEN-B disabled)	No effect (OPEN-A disabled)	No effect (OPEN-B disabled)	lighted
AT CLOSING	Inverts in apertura	No effect	Stops operation	No effect	Stops operation (OPEN-B disabled)	flashing
AT OPENING	No effect	No effect		No effect (OPEN-A disabled)	Stops operation (OPEN-A/B disabled)	lighted
LOCKED	Opens the leaf or leaves	Closes the leaves or leaf	No effect (OPEN-A/B disabled)	No effect (OPEN-A disabled)	No effect (OPEN-B disabled)	lighted

Table 3/f

PULSES						
COMMANDS ALWAYS PRESSED						
LOGIC "C"	OPEN-A	OPEN-B	STOP	OPENING SAFETY DEVICES	CLOSING SAFETY DEVICES	W.L.
GATE STATUS						
CLOSED	Opens the leaf or leaves	No effect	No effect (OPEN-A disabled)	No effect (OPEN-A disabled)	No effect (OPEN-B disabled)	OFF
OPEN	No effect	Closes the leaves or leaf	No effect (OPEN-B disabled)	No effect (OPEN-A disabled)	No effect (OPEN-B disabled)	lighted
AT CLOSING	Stops operation		Stops operation	No effect (OPEN-B disabled)	Stops operation (OPEN-B disabled)	flashing
AT OPENING		Stops operation		Stops operation (OPEN-A disabled)	No effect	lighted

1. If maintained, it prolongs the pause until disabled by the command (timer function)
 2. If remaining pause time is shorter than 5 sec., when safety devices are released, it closes after 5 sec.
- NB.:** Effects on other active pulse inputs in brackets.